

STRAINER

CLASS 150 BRONZE

Y-Pattern • Threaded Cap and Ends
Stainless Steel (304) Punched Screen

CODE # 15 (AKYU) THREADED

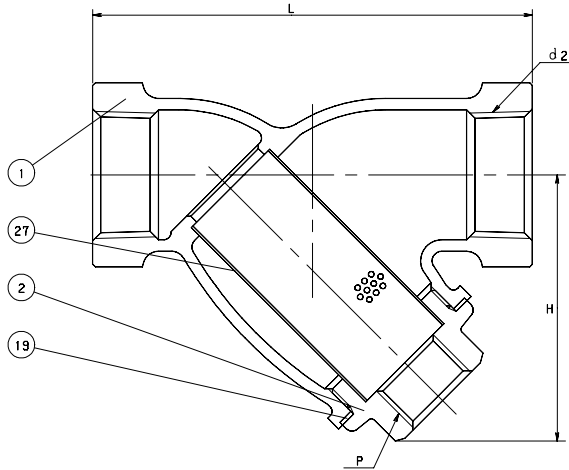

STANDARDS	
END TO END	KITZ
THREADED ENDS	ANSI B1.20.1
SOLDER JOINT ENDS	ANSI B16.18
WALL THICKNESS	KITZ
DESIGN	KITZ

PRESSURE/TEMPERATURE
150 PSI - SATURATED STEAM TO 366°F - FLUID TO 406°F
300 PSI NON-SHOCK COLD WATER, OIL OR GAS

*SEE PRESSURE/TEMPERATURE LIMITATIONS FOR SOLDER JOINT VALVES - PAGE BIV-50.

MATERIAL LIST		
NO.	NAME OF PART	SPECIFICATION
1	BODY	CAST BRONZE (B584, C84400)
2	*CAP	FORGED BRASS (B283, C37700)
19	GASKET	NON-ASBESTOS SHEET
27	SCREEN	STAINLESS STEEL (A167, TYPE 304)

* Cap supplied without plug. Blind cap optionally available.

CODE # 16 (CYU) SOLDER*

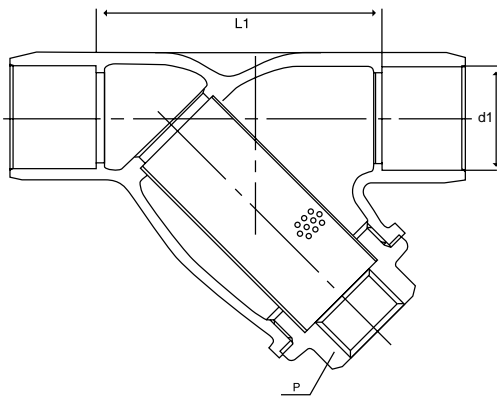

DIMENSIONS - WEIGHTS - QUANTITIES								
d2 SIZE	H	L	P	L1	d1		APPROX. NET WT.	CARTON QTY
					Max.	Min.		
1/4	1.73	2.76	1/4	-	-	-	0.56	96
3/8	1.73	2.76	1/4	-	.506	.502	0.56	96
1/2	1.93	3.15	1/4	2.15	.631	.627	0.76	80
3/4	2.28	3.94	1/4	2.63	.881	.877	1.29	48
1	2.80	4.53	1/2	3.10	1.132	1.128	1.86	36
1 1/4	3.19	5.31	1/2	3.77	1.382	1.378	2.92	24
1 1/2	3.82	6.30	3/4	4.51	1.633	1.628	4.31	16
2	4.72	7.68	1	5.59	2.133	2.128	7.25	8
2 1/2	5.83	9.06	1 1/4	-	2.633	2.628	13.00	1
3	7.09	9.45	1 1/2	-	3.133	3.128	19.00	1

NOTE: The standard punched screen is approximately 12 mesh screen. Other mesh screens are available (see spare parts in price sheet).

**NOTE: NOT INTENDED FOR USE IN A POTABLE WATER SYSTEM - COMPLIANT STATEMENT
PROP 65, STATE OF CALIFORNIA**