

STRAINER

CLASS 125 CAST IRON

Y-Pattern • Bolted Cover • Blow-out-Plug
Stainless Steel (304) Screen

CODE # 80 (125FCYU)

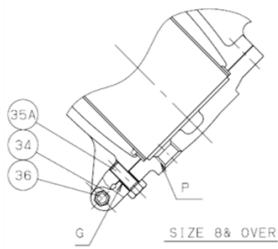
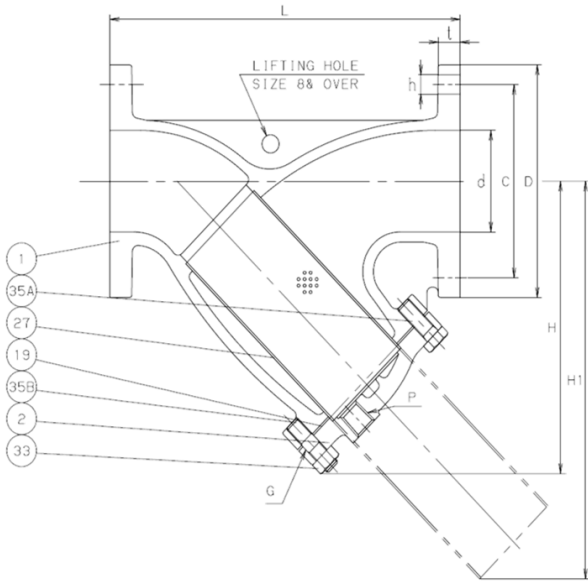

STANDARDS	
END TO END	KITZ
END CONNECTION	ANSI B16.1, CLASS 125
WALL THICKNESS	KITZ
DESIGN	KITZ

PRESSURE/TEMPERATURE
125 PSI - SATURATED STEAM TO 353°F - FLUID TO 450°F
200 PSI NON-SHOCK COLD WATER, OIL OR GAS

MATERIAL LIST		
NO.	NAME OF PART	SPECIFICATION
1	BODY	CAST IRON (A126 CLASS B)
2	COVER	CAST IRON (A126 CLASS B)
19	GASKET	GRAPHITE
27	SCREEN	STAINLESS STEEL (TYPE 304)
33	COVER NUT	CARBON STEEL (CLASS 4)
34	COVER HINGE NUT	CARBON STEEL
35A	COVER BOLT (8-12)	CARBON STEEL (CLASS 4.8)
35B	COVER BOLT (2-6)	CARBON STEEL (A307 Gr.B)
36	COVER HINGE BOLT	CARBON STEEL

DIMENSIONS - WEIGHTS												
SIZE	d	L	H	H1	D	P	BOLT HOLE		BOLT		t	APPROX. NET WT.
							C	No.	h	SIZE		
2	1.97	9.84	6.18	8.20	6.00	1/2	4.75	4	3/4	5/8	0.62	30
2 1/2	2.56	11.22	8.15	11.40	7.00	1	5.50	4	3/4	5/8	0.69	34
3	3.15	12.40	9.33	13.20	7.50	1 1/4	6.00	4	3/4	5/8	0.75	42
4	3.94	14.57	10.94	15.30	9.00	1 1/2	7.50	8	3/4	5/8	0.94	73
5	4.92	16.54	12.64	17.60	10.00	2	8.50	8	7/8	3/4	0.94	100
6	5.91	19.29	14.45	19.60	11.00	2	9.50	8	7/8	3/4	1.00	166
8	7.87	22.44	17.99	24.50	13.50	2	11.75	8	7/8	3/4	1.12	242
10	9.84	26.77	21.10	29.30	16.00	2	14.25	12	1	7/8	1.19	428
12	11.81	31.50	24.61	34.20	19.00	2	17.00	12	1	7/8	1.25	585

CAST IRON STRAINER