

FORGED BRASS BALL VALVE

CAP & CHAIN

Two Piece Body • Full Port

Blowout Proof Stem • Chrome Plated Ball • PTFE Seats and Seals

CODE # 68C (AKT AFC) THREADED x HOSE

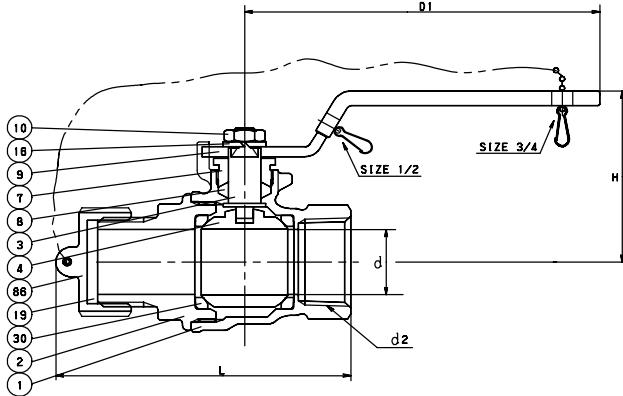

CODE # 69C (CTAFC) SOLDER* x HOSE

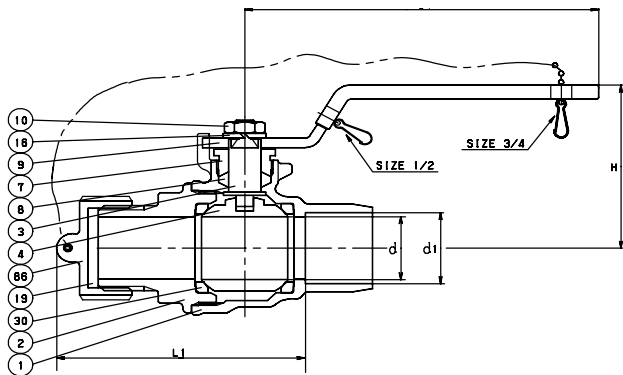

*REFERENCE VALVE INSTALLATION TIPS FOR SOUND SOLDER JOINTS (PAGE BV-66) OR SEE INSTALLATION SHEET PACKAGED WITH VALVE.

SPECIFICATION

Approved valve shall have two piece forged brass body, chrome plated ball, blowout proof stem, PTFE seats/seals, PP or brass cap & chain and full port design. Valves shall be pressure rated to 150 WSP/600 WOG and conform to MSS-SP 110.

KITZ Code No. 68C (AKT AFC) Threaded Ends
69C (CTAFC) Solder Ends

STANDARDS

END TO END	KITZ
THREADED ENDS	ANSI B1.20.1/ANSI B2.4 3/4 11.5 NHR
SOLDER JOINT ENDS	ANSI B16.18/ANSI B2.4 3/4 11.5 NHR
WALL THICKNESS	KITZ
CONFORMS TO MSS-SP 110	

PRESSURE/TEMPERATURE

150 PSI - SATURATED STEAM TO 366°F
600 PSI - NON-SHOCK COLD WATER, OIL OR GAS

NOTE: PRESSURE/TEMPERATURE CHART - PAGE BV-29

MATERIAL LIST

NO.	NAME OF PART	SPECIFICATION
1	BODY	FORGED BRASS (B283, C37700)
2	BODY CAP	BRASS ROD (B16) (3/4")
3	STEM	(1) SPECIAL BRASS (KITZ, "K-METAL")
4	BALL	(2) FORGED BRASS (B283, C37700)
7	GLAND	BRASS ROD (B16)
8	GLAND PACKING	PTFE
9	HANDLE	(3) CARBON STEEL
10	HANDLE NUT	CARBON STEEL
16	SPRING WASHER	CARBON STEEL
19	GASKET	NBR
30	BALL SEATS	PTFE
86	CAP & CHAIN	PP/BRASS

NOTES: (1) PROPRIETARY DEZINCIFICATION RESISTANT MATERIAL.
(2) CR. PLATING
(3) ELECTROPLATED ZINC WITH PLASTIC COVERING

DIMENSIONS - WEIGHTS - QUANTITIES

d2 SIZE	d	H	D1	L	L1	d1		APPROX. CARTON NET WT.	QTY
						Max.	Min.		
1/2	.59	1.65	3.23	2.93	2.46	.631	.627	52	96
3/4	.79	2.01	3.94	3.30	2.79	.881	.877	50	60