

# GATE

## CLASS 150 BRONZE

Screw-In Bonnet • Inside Screw • Non-Rising Stem  
Solid Wedge Disc

**CODE # 46 (AK150E)**  
**THREADED**

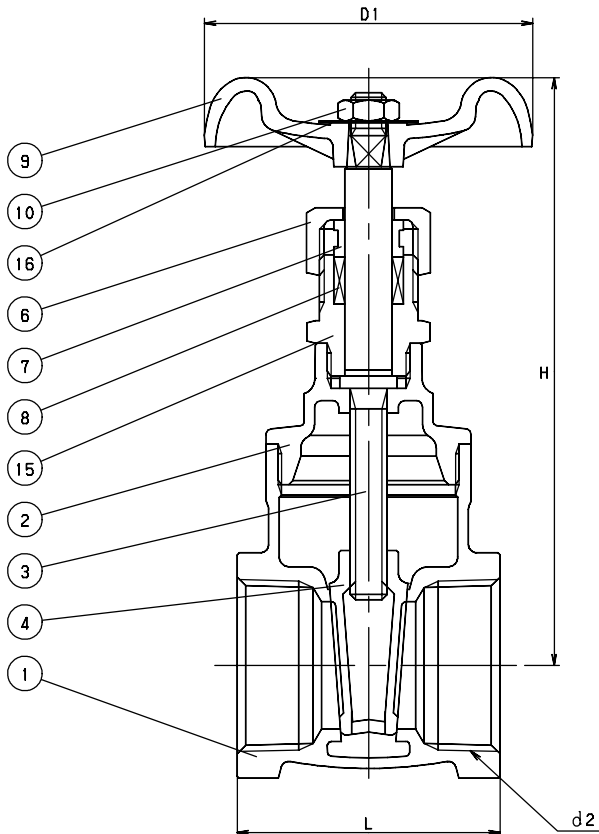

### STANDARDS

|               |                    |
|---------------|--------------------|
| END TO END    | KITZ               |
| THREADED ENDS | ANSI B1.20.1       |
| DESIGN        | MSS SP-80, TYPE 1A |
| MILITARY      | MSS SP-80, TYPE 1A |

### PRESSURE/TEMPERATURE

|  |
|--|
| 150 PSI - SATURATED STEAM TO 366°F<br>- FLUID TO 406°F<br>300 PSI NON-SHOCK COLD WATER, OIL OR GAS |
|--|

### MATERIAL LIST

| NO. | NAME OF PART                        | SPECIFICATION                                  |
|-----|-------------------------------------|--|
| 1   | BODY                                | CAST BRONZE (ASTM B62)                         |
| 2   | BONNET                              | CAST BRONZE (ASTM B62)                         |
| 3   | STEM                                | CAST BRONZE (ASTM B62)                         |
| 4   | DISC                                | CAST BRONZE (ASTM B62)                         |
| 6   | PACKING NUT                         | FORGED BRASS (B283, C37700)                    |
| 7   | GLAND                               | BRASS ROD (B16)                                |
| 8   | GLAND PACKING                       | ARAMID FIBERS W/ GRAPHITE                      |
| 9   | HAND WHEEL (3/8 - 1)<br>(1 1/4 - 2) | ZINC DIE-CAST (B86)<br>ALUMINUM DIE-CAST (B85) |
| 10  | WHEEL NUT                           | BRASS ROD                                      |
| 15  | STUFFING BOX (3/8 - 1 1/2)<br>(2)   | BRASS ROD (B16)<br>FORGED BRASS (B283, 37700)  |
| 16  | NAME PLATE                          | ALUMINUM                                       |

### DIMENSIONS - WEIGHTS - QUANTITIES

| SIZE<br>d2 | H    | D1   | L    | APPROX. NET WT. | CARTON QTY |
|------------|------|------|------|-----------------|------------|
| 3/8        | 3.39 | 1.97 | 1.69 | 0.68            | 96         |
| 1/2        | 3.86 | 2.17 | 1.93 | 0.97            | 72         |
| 3/4        | 4.49 | 2.76 | 2.09 | 1.24            | 54         |
| 1          | 4.96 | 2.76 | 2.40 | 1.72            | 36         |
| 1 1/4      | 5.70 | 3.15 | 2.68 | 2.75            | 24         |
| 1 1/2      | 6.92 | 3.54 | 2.91 | 4.06            | 16         |
| 2          | 7.91 | 3.94 | 3.31 | 6.38            | 8          |