

# CHECK

## CLASS 125 BRONZE

Screw Cap • Integral Seat • Horizontal Swing Type Disc  
T-Pattern

### CODE # 04 (AKR) THREADED

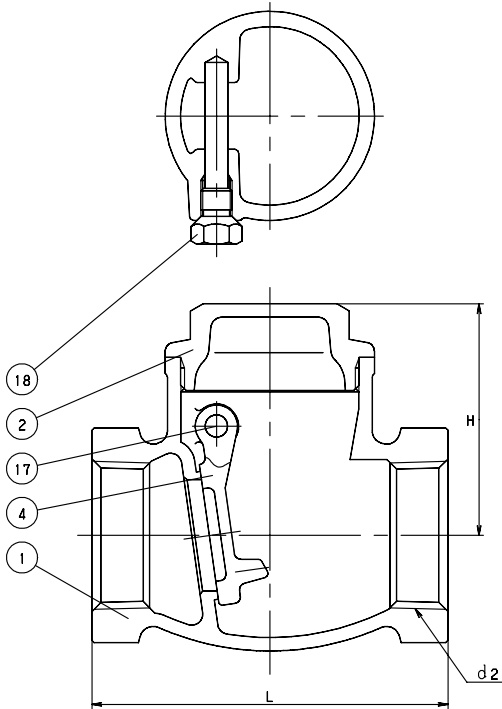

### CODE # 14 (CR) SOLDER\*

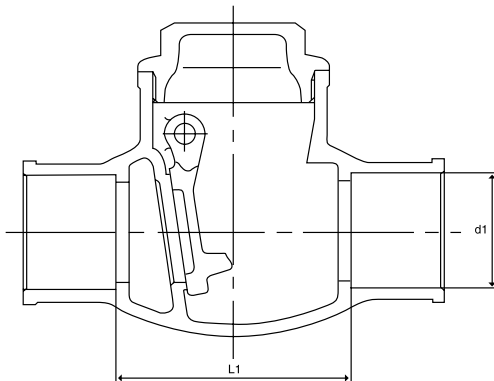

#### STANDARDS

END TO END	KITZ
THREADED ENDS	ANSI B1.20.1
SOLDER JOINT ENDS	ANSI B16.18
DESIGN	MSS SP-80, Type 3

#### PRESSURE/TEMPERATURE

125 PSI - SATURATED STEAM TO 353°F  
- FLUID TO 406°F

200 PSI NON-SHOCK COLD WATER, OIL OR GAS

\*SEE PRESSURE/TEMPERATURE LIMITATIONS FOR SOLDER JOINT  
VALVES - PAGE BIV-50.

#### MATERIAL LIST

NO.	NAME OF PART	SPECIFICATION
1	BODY	CAST BRONZE (B62)
2	CAP (3/8 - 3)	FORGED BRASS (B283, C37700)
	(4)	CAST BRONZE (B62)
4	DISC (3/8 - 3)	FORGED BRASS (B283, C37700)
	(4)	CAST BRONZE (B62)
17	HINGE PIN	FORGED BRASS (B16)
18	PLUG	BRASS ROD (B16)

#### DIMENSIONS - WEIGHTS - QUANTITIES

d2 SIZE	H	L	L1	d1		APPROX. NET WT.	CARTON QTY
				Max.	Min.		
3/8	1.54	2.09	-	.506	.502	0.53	96
1/2	1.54	2.36	1.64	.631	.627	0.68	96
3/4	1.77	2.76	1.88	.881	.877	1.00	60
1	2.05	3.15	2.31	1.132	1.128	1.54	48
1 1/4	2.44	3.62	2.83	1.382	1.378	2.33	24
1 1/2	2.64	4.02	3.21	1.633	1.628	3.00	18
2	3.11	4.80	4.02	2.133	2.128	4.92	12
2 1/2	3.58	5.91	4.69	2.633	2.628	7.75	8
3	4.02	6.50	5.42	3.133	3.128	10.33	6
4	4.69	7.68	-	-	-	16.00	4