

F14A (F18A for 14" - 16")

Full and Regular Port, 2-piece body construction.

Standards: • Design: ASME B16.34 • Wall Thickness: ASME B16.34 • Flanges: ASME B16.5 • Test: API 598 • FSM: API 607
• Top Flange: ISO5211 Face to Face: ASME B16.10 (Short and Long pattern).

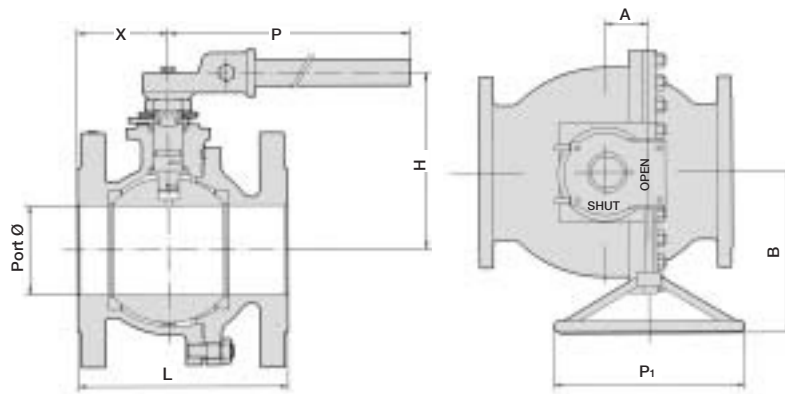

ASME 600									
FULL PORT									
VALVE SIZE	Port	DIMENSIONS, inches				ISO 5211 Flange	Cv	Torque (in lbs.) A600	Weight (lbs.)
		L	X	P	H				
1/2"	.55	6.5	3.2	5.9	3.4	F03	18	56	6.4
3/4"	.75	7.5	3.7	5.9	3.5		40	86	9.3
1"	1.00	8.5	4.3	5.9	3.9	F05	65	133	13
1 1/2"	1.50	9.5	4	7.9	4.7		150	265	25.4
2"	2	11.5	4.6	13.8	5	F07	260	354	38.6
3"	3	14	5.4	13.8	5.8		980	1062	76.5
4"	4	17	8.5	19.7	7.7	F10	1600	2213 ⁽³⁾	151

REGULAR PORT									
VALVE SIZE	Port	DIMENSIONS, inches				ISO 5211	Cv	Torque (in lbs.) A600	Weight (lbs.)
		L	X	P	H				
6"	4.38	22	11	39.4	10	F10	1020	2000 ⁽¹⁾	243

Gear Box					
FULL PORT					
VALVE SIZE	Model	Input / Output (max.) (in-lbs.)	A	B	P1
4"-6"	RM.551	850/8266	2.8	11.1	12.8

⁽¹⁾ Values according to the pressure limitations of seats. See page 3-4.

STANDARD MATERIALS

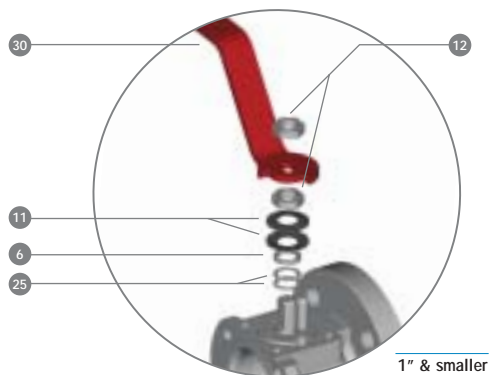

1" & smaller

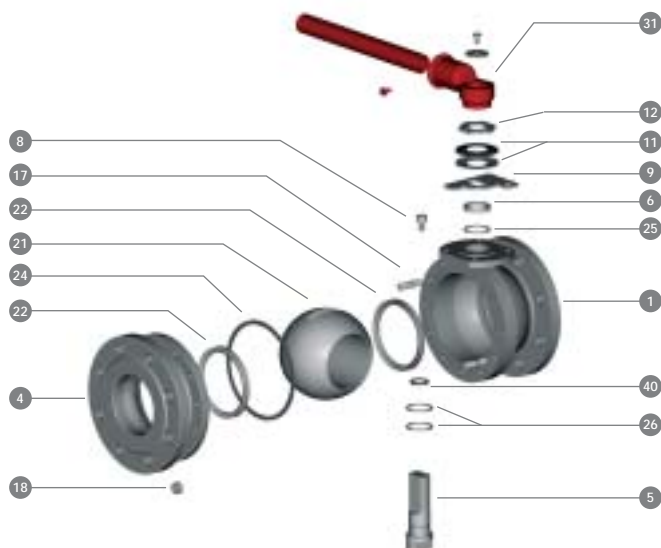

Body Group			
Item	Component	Code SS	Code CS
1	Body	ASTM A351 (CF8M)	ASTM A216 WCC* * WCC = WCB (0.25% C Max.)
4	Cap	ASTM A351 (CF8M)	ASTM A216 WCC* * WCC = WCB (0.25% C Max.)
17	Cap Bolt	ANSI 150:	ASTM A193 B7M + deltatone
18	Cap Nut	ASTM A194 GrB7M + deltatone	ASTM A193 2HM + deltatone
		ANSI 300:	
		A194 GrB7M + deltatone	
		ANSI 600:	
		ASTM A193/A194 B7M/2HM deltatone coat	
11	Belleville Washer	Stainless steel	Carbon Steel
12	Nut	Stainless steel	Carbon Steel
8	Stop Pin	Stainless steel	Stainless Steel
30-31	Handle	≤ 1": SS + Plastic > 1": Cast Iron	≤ 1": SS & Plastic > 1": Cast Iron
9	Stop Plate	Steel nickel plated	Steel zinc plated

Internal Group		
Item	Component	Code 316
21	Ball	≤ 1": ASTM A479 316 ≥ 1 1/2": ASTM A351 (CF8M)
5	Stem	ASTM A479 316
6	Gland Ring	ASTM A479 316

Seal Group			
Item	Component	Code PTFE	Code FSM
22	Seat	PTFE*	PTFE*
24	Body Seal	≤ 1": PTFE ≥ 1 1/2": 316L + Flexite®	316L + Graphite
25	Gland Packing	≤ 1": PTFE ≥ 1 1/2": PTFE	Graphite
26	Stem Seal	PTFE	PTFE + C + Graphite
40	Stem O-Ring	FPM (Viton®)	FPM (Viton®)

Valve Finish: (CS) ≤ 6": phosphate and oil dipped.

≥ 8": base primer 40 µm min.

Operation: ≤ 6": lever. ≥ 8": gear box.

*For alternate materials please contact KCA.

Pressure – Temperature (P – T) ratings:

The P – T operating ratings in soft-seated floating ball valves are not only determined by the resistance of the Valve Body, but also by the limitations of their Seats and Seals. It is difficult to pinpoint the accurate P – T limit because of the boundless number of combinations between fluids and conditions. This is why the values that are shown below are an approximation and based on our own past experience.



Virgin PTFE: Inert to most media, low friction coefficient, subject to temperature limitations. Good performance in gas applications.



PTFE + Graphite (20% C + 5% Graph): Inert to most media. Higher P-T range than virgin PTFE. Used in steam and thermal oil applications.

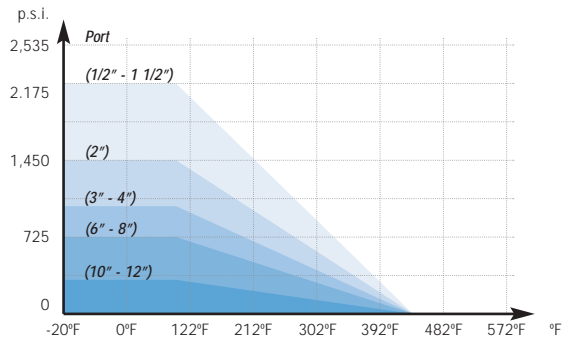
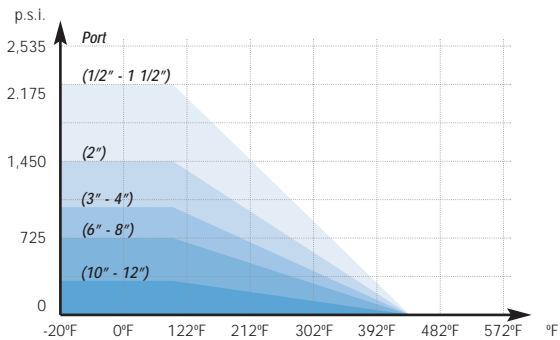

PTFE + Glass Fiber (15% G.F.): Good resistance to wear and deformation under load. Longer service life and higher pressure resistance than virgin PTFE. Suitable for foodstuffs, pharmaceutical and cosmetic industry applications.



PTFE + Glass Fiber (25% G.F.): Good resistance to wear and deformation under load. Longer service life and higher pressure resistance than PTFE + 15% G.F. Suitable for foodstuffs, pharmaceutical and cosmetic industry applications.

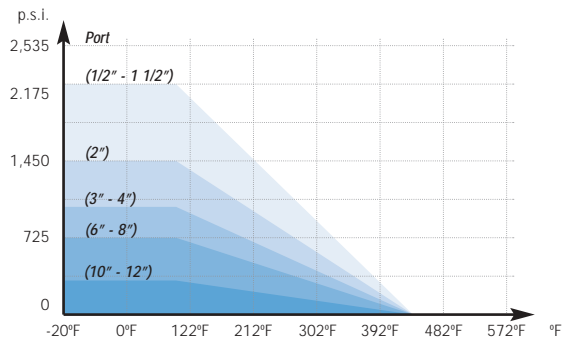
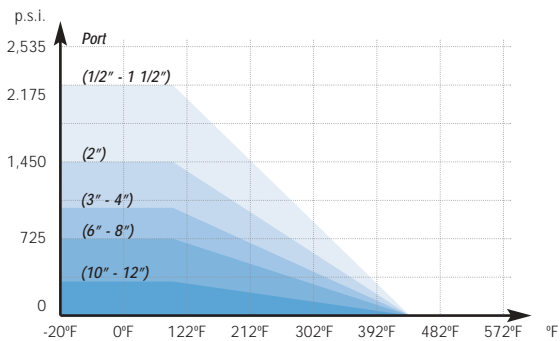



HYPATITE (PTFE + PFA + compound):
Good resistance to wear and under load. Higher chemical resistance than virgin PTFE.



PTFE + 50% SS (Stainless Steel): Good pressure resistance. Used for abrasive fluids or hard particles transportation.

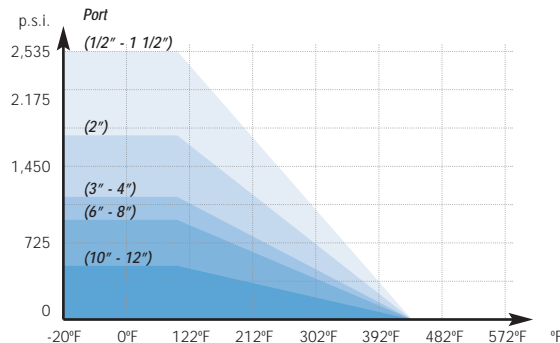
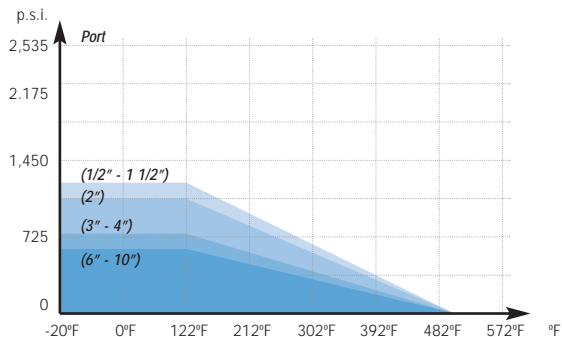

PEEK (Poly-ether-ether-ketone): Suitable for tobacco, nuclear services and high temperatures at high pressure. High friction. Not recommended for concentrated Sulphuric Acid.



UHMWPE (Ultra High Molecular Weight Polyethylene): Good for nuclear, tobacco, food industry, H₂SO₄, etc. Low friction coefficient.

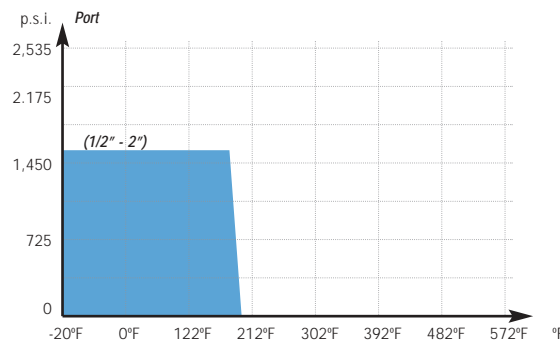
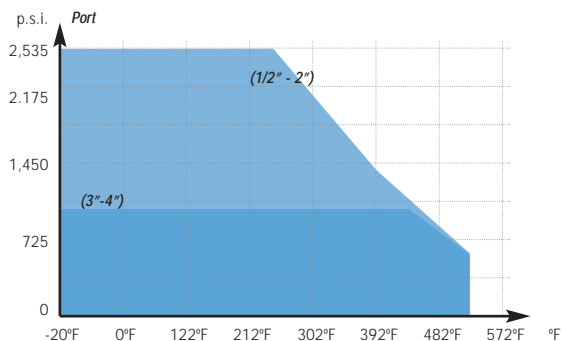

Note: Other sealing materials, like TFM 1600, Polypropylene, PEEK+Graphite, FEP+Silicone, Fluoraz®, Kalrez®, Chemraz®, etc, are available upon request.

O-Ring Materials			
Type	ASTM Designation	Temperature	
		Standard	Low Temp.
Viton®	FPM/FKM Fluorocarbon Rubber	-13 °F / +446 °F	-40 °F / 446 °F
Nitrile	NBR Nitrile Butadiene Rubber	-13 °F / +284 °F	-67 °F / +230 °F