

DUAL DISC SILENT WAFER CHECK VALVE - 200 WOG

Cast Iron Body - 316SS Disc - Buna or EPDM Seat
SIZE 2" - 12"

Code No. 7032

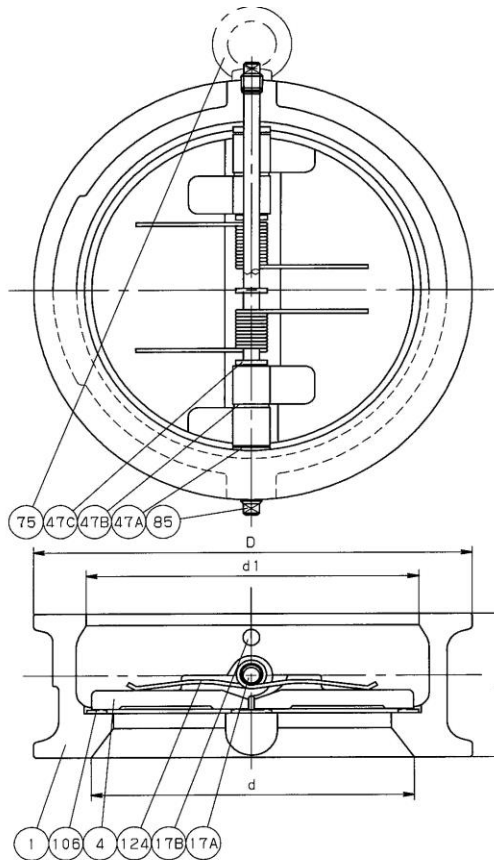

MOUNTING RECOMMENDATIONS

Suitable for installation in horizontal, or vertical piping with upward flow.

When mounted in horizontal piping, the Hinge Pin must be vertical.

Valve should be mounted a minimum of six times the nominal pipe diameter from pumps, elbows or other transition devices in the piping system.

STANDARDS

END TO END	KITZ Standard
END CONNECTIONS	Mounts between Class 125/150 Flanges
WALL THICKNESS	KITZ Standard
SHUTOFF	Bubble Tight - KITZ Standard

PRESSURE - TEMPERATURE

200 PSI (1.38 MPa) WOG, Non-Shock @ 150F

Buna - 195 psi @ 176F (1.34 MPa @ 80C)

EPDM - 185 psi @ 212F (1.27 MPa @ 100C)

Not suitable for Steam service.

MATERIAL LIST

No.	Name of Part	Specification
1	BODY	A126 Class B
4	DISC	A351, Gr. CF8M (316SS)
16	NAME PLATE	Stainless Steel (not shown)
17A	HINGE PIN	A276 Type 304
17B	STOP PIN	A276 Type 304
47A	BODY BEARING	PTFE
47B	BODY BEARING	PTFE
47C	SPRING BEARING (A)	PTFE
75	EYE BOLT (B)	Steel
85	PLUG	A276 Type 304
106	SEAT (C)	NBR/EPDM
124	SPRING (D)	A313 Type 316

Foot Notes

- (A) Spring Bearings - 2 used in 2"~5", 3 in 6"~12"
- (B) Eye Bolt - 6"~12" only
- (C) Vulcanized to Body
- (D) Single Spring in 2"~5", double in 6"~12"

Code No.

7032B - Buna Seat
7032E - EPDM Seat

Unit: Inch

SIZE	DIMENSIONS				
	d	d1	D	L	Bolting
2	2.60	2.36	4.13	2.13	5/8-11 x 5.1/2
2 1/2	2.68	2.87	4.88	2.13	5/8-11 x 5 7/8
3	3.23	3.50	5.39	2.24	5/8-11 x 6
4	4.41	4.49	6.89	2.52	5/8-11 x 6 1/4
5	5.28	5.55	7.76	2.76	3/4-10 x 6 7/8
6	6.69	6.61	8.74	2.99	3/4-10 x 7 5/16
8	8.15	8.62	10.98	3.74	3/4-10 x 8 1/8
10	10.35	10.75	13.39	4.32	7/8-9 x 9 1/16
12	12.01	12.76	16.14	5.63	7/8-9 x 10 5/8