



KITZ Corporation Of America
800-772-0073 • www.KITZ.com

THREADED CARBON STEEL BALL VALVE
Three Piece • Regular Port • Stainless Steel Trim • Hypatite Seats
ISO 5211 Mounting Pad (KITZ Standard Mounting Pad on 1/2")
Locking Oval Handle • Encapsulated Body Bolts • 1500 WOG • NACE

**AKSC3THZM-O
CODE NO. 317-LOH**

MATERIAL LIST

No.	Name of Parts	Materials
1	BODY	A216 Gr. WCB
2	CAP	A216 Gr. WCB
3	STEM	A276 TYPE 316
4	BALL	A276 TYPE 316 or A351 Gr. CF8M
7	GLAND	A276 TYPE 316
8	GLAND PACKING	PTFE
9	HANDLE	A276 TYPE 430 (1)
10	HANDLE NUT	A194 Gr. 8
16A	WASHER	STAINLESS STEEL
16B	NAME PLATE	STAINLESS STEEL
19	GASKET	PTFE
30	BALL SEAT	HYPATITE PTFE
34	GLAND NUT	A194 Gr. 8
35	CAP BOLT	A193 Gr. 8B
40	LOCK PLATE	STAINLESS STEEL
43	CONED DISC SPRING	STAINLESS STEEL
47	THRUST WASHER	25% CARBON FILLED PTFE (2)
126	STOPPER PIN	A276 TYPE 304
A	LATCH LOCK	STAINLESS STEEL

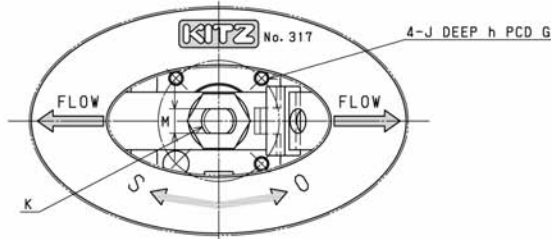

NOTE

- (1) Plastic covering.
- (2) All valves have an anti-static thrust washer insuring positive conductivity between body and stem.

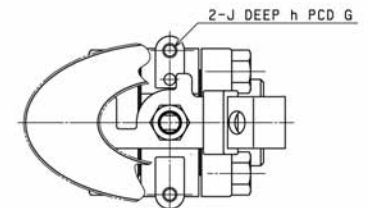
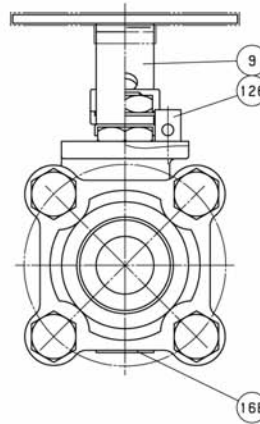
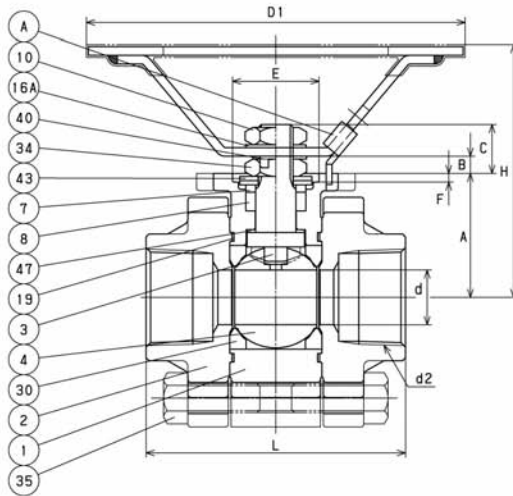

SIZE 1/2 ONLY

DIMENSIONS

Unit : inch

Nominal Size	Mounting Dimensions for Actuator															
	d	H	D1	L	d2	A	B	C	E	F	G	J	h	K	M	ISO 5211 Flange Type
1/2	0.39	2.48	3.94	2.48	NPT 1/2	1.043	0.079	0.413	—	—	1.969	1/4-20UNC	0.275	M8	0.197	—
3/4	0.55	3.07	5.12	2.80	NPT 3/4	1.378	0.169	1.559	0.984	0.118	1.417	1/4-20UNC	0.197	M10	0.236	F03
1	0.75	3.43	5.12	3.54	NPT 1	1.693	0.197	0.669	1.181	0.118	1.654	1/4-20UNC	0.315	M12	0.335	F04



KITZ Corporation Of America
800-772-0073 • www.KITZ.com

THREADED CARBON STEEL BALL VALVE
Three Piece • Regular Port • Stainless Steel Trim • Hypatite Seats
ISO 5211 Mounting Pad (KITZ Standard Mounting Pad on 1/2")
Locking Lever Handle • Encapsulated Body Bolts • 1500 WOG • NACE

**AKSC3THZM
CODE NO. 317**

MATERIAL LIST

No.	Name of Parts	Materials
1	BODY	A216 Gr. WCB
2	CAP	A216 Gr. WCB
3	STEM	A276 TYPE 316
4	BALL	A276 TYPE 316 or A351 Gr. CF8M
7	GLAND	A276 TYPE 316
8	GLAND PACKING	PTFE
9	HANDLE	A276 TYPE 430 (1)
10	HANDLE NUT	A194 Gr. 8
16A	WASHER	STAINLESS STEEL
16B	NAME PLATE	STAINLESS STEEL
19	GASKET	PTFE
30	BALL SEAT	HYPATITE PTFE
34	GLAND NUT	A194 Gr. 8
35	CAP BOLT	A193 Gr. BB
40	LOCK PLATE	STAINLESS STEEL
43	CONED DISC SPRING	STAINLESS STEEL
47	THRUST WASHER	25% CARBON FILLED PTFE (2)
126	STOPPER PIN	A276 TYPE 304
A	LATCH LOCK	STAINLESS STEEL

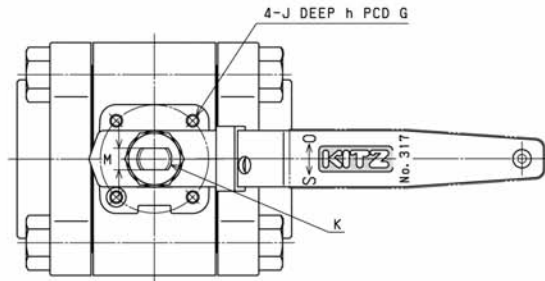

NOTE

- (1) Plastic covering.
- (2) All valves have an anti-static thrust washer insuring positive conductivity between body and stem.

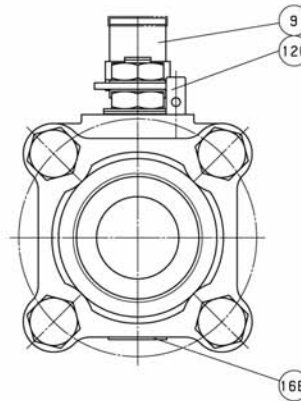
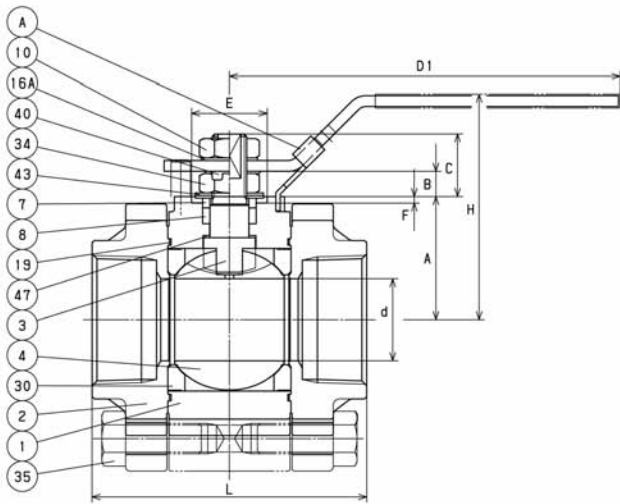

DIMENSIONS

Unit : inch

Nominal Size	Mounting Dimensions for Actuator														ISO 5211 Flange Type	
	in.	d	H	D1	L	d2	A	B	C	E	F	G	J	h		K
1 1/4	0.94	3.23	5.91	4.06	NPT 1 1/4	1.732	0.531	1.083	1.181	0.118	1.654	1/4-20UNC	0.315	M14	0.394	F04
1 1/2	1.18	3.46	5.91	4.33	NPT 1 1/2	1.949	0.531	1.071	1.181	0.118	1.654	1/4-20UNC	0.315	M14	0.394	F04
2	1.50	4.09	7.09	5.00	NPT 2	2.244	0.461	1.142	1.378	0.118	1.969	1/4-20UNC	0.394	M16	0.394	F05