

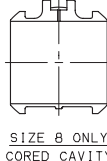

300SCTDZM 300SCTDZM-FS

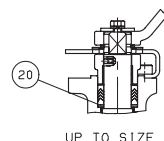
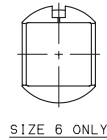
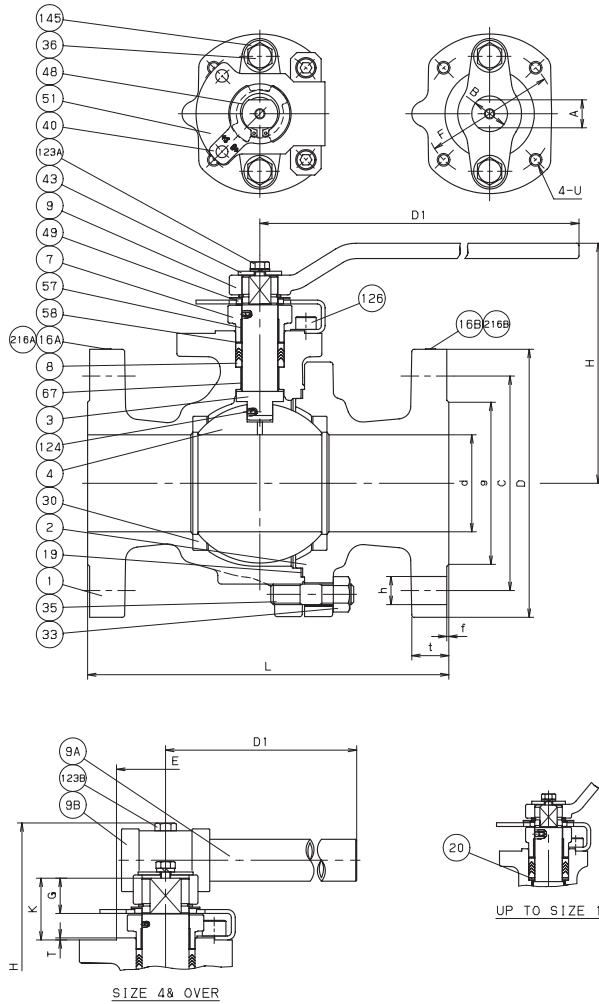

MATERIAL LIST

No.	Name of Parts	Materials
1	BODY	A216 Gr. WCB
2	BODY CAP	A216 Gr. WCB
3	STEM	A276 TYPE316
4	BALL	A276 TYPE316 or A351 Gr. CF8M
7	GLAND	A351 Gr. CF8
8	GLAND PACKING	300SCTDZM PTFE 300SCTDZM-FS FLEXIBLE GRAPHITE
9	HANDLE	DUCTILE IRON(UP TO SIZE 3)
9 A	HANDLE BAR	CARBON STEEL(SIZE 4 & OVER)
9 B	HANDLE HEAD	DUCTILE IRON(SIZE 4 & OVER)
16 A	NAME PLATE	A276 TYPE304
16 B	LEV PLATE	A276 TYPE304
19	GASKET	300SCTDZM PTFE 300SCTDZM-FS FLEXIBLE GRAPHITE
20	PACKING WASHER	A276 TYPE316L(UP TO SIZE 1)
30	BALL SEAT	HYPATITE® PTFE
33	CAP NUT	A194 Gr. 2HM
35	CAP BOLT	A193 Gr. B7M
36	GLAND BOLT	STAINLESS STEEL
40	KEYLOCK PLATE	A276 TYPE304
43	HANDLELOCK PLATE	A276 TYPE304
48	SNAP RING	A276 TYPE304
49	STOPPER	A276 TYPE304
51	STOPPER PLATE	A276 TYPE304
57	GLAND BUSHING	G/F PTFE
58	GLAND WASHER	A276 TYPE304
67	STEM BEARING	G/F PTFE
123 A	HANDLELOCK PLATE BOLT	STAINLESS STEEL
123 B	HANDLE BOLT	STAINLESS STEEL
124	SPRING & PIN	A313 & A276 TYPE316
126	STOPPER PLATE BOLT	STAINLESS STEEL
145	CONED DISC SPRINGS	Inconel® 718 or Equivalent
216 A	CE PLATE	A276 TYPE304(SIZE 1 1/2 & OVER)
216 B	ATEX PLATE	A276 TYPE304

DIMENSIONS

Unit : inch

Nominal Size	End Flange										Mounting Dimensions for Actuator										ISO 5211 Flange Type	
	in.	mm	d	H	D1	L	D	Bolt Hole		Bolt Size	g	t	f	A	B	E	F	G	K	T		U
1/2	15	0.55	4.25	5.12	5.50	3.75	2.62	4	0.62	1/2	1.38	0.56	0.06	0.36	0.47	0.99	1.42	0.35	0.87	0.04	M5	F03
3/4	20	0.75	4.37	5.12	6.00	4.62	3.25	4	0.75	5/8	1.69	0.62	0.06	0.36	0.47	0.99	1.42	0.35	0.87	0.04	M5	F03
1	25	0.95	4.88	7.09	6.50	4.88	3.50	4	0.75	5/8	2.00	0.69	0.06	0.55	0.71	1.38	1.97	0.55	1.18	0.06	M6	F05
1 1/2	40	1.50	5.28	9.06	7.50	6.14	4.50	4	0.88	3/4	2.88	0.81	0.06	0.67	0.87	2.17	2.76	0.67	1.34	0.06	M8	F07
2	50	1.97	5.63	9.06	8.50	6.50	5.00	8	0.75	5/8	3.62	0.88	0.06	0.67	0.87	2.17	2.76	0.67	1.34	0.06	M8	F07
2 1/2	65	2.52	7.05	15.75	9.50	7.50	5.88	8	0.88	3/4	4.12	1.00	0.06	0.87	1.10	2.76	4.02	0.87	1.77	0.08	M10	F10
3	80	3.00	7.44	15.75	11.12	8.25	6.62	8	0.88	3/4	5.00	1.12	0.06	0.87	1.10	2.76	4.02	0.87	1.77	0.08	M10	F10
4	100	3.94	8.82	29.53	12.00	10.00	7.88	8	0.88	3/4	6.19	1.25	0.06	1.06	1.42	3.35	4.92	1.06	2.05	0.08	M12	F12
6	150	5.95	12.40	39.37	15.88	12.50	10.62	12	0.88	3/4	8.50	1.44	0.06	1.42	1.89	3.94	5.51	1.42	2.48	0.08	M16	F14
8	200	7.95	15.98	59.06	19.75	15.00	13.00	12	1.00	7/8	10.62	1.62	0.06	1.81	2.36	5.12	6.50	1.81	3.11	0.08	M20	F16