



KITZ Corporation Of America  
800-772-0073 • www.KITZ.com

**THREADED CARBON STEEL BALL VALVE**  
Two Piece Seal Welded • Regular Port • Stainless Steel Trim • Hypatite Seats  
Integral Mounting Pad • Locking Lever Handle  
Firesafe in Accordance with API 607  
2000 WOG (1/4"-1") and 1500 WOG (1-1/4"-2") • NACE

**AKSCTHWZM-FS  
CODE NO. 239**

**MATERIAL LIST**

No.	Name of Parts	Materials
1	BODY	A216 Gr. WCB
2	BODY CAP	A216 Gr. WCB
3	STEM	A276 TYPE 316
4	BALL	A276 TYPE 316
7	GLAND	A276 TYPE 304
8	GLAND PACKING	FLEXIBLE GRAPHITE
9	HANDLE	CARBON STEEL (1)
10	HANDLE NUT	A194 Gr. 8
16	WASHER	A276 TYPE 304 (SIZE 1/2 & OVER)
30	BALL SEAT	HYPATITE PTFE
47	THRUST WASHER	G/F PTFE
A	LATCH LOCK	A276 TYPE 304

**NOTE**

- (1) Plastic covering.
- (2) BS 5351 Class 800 (size 1/4 to 1), KITZ standard (size 1 1/4 to 2).
- (3) Valve rating 2000WOG (size 1/4 to 1), 1500WOG (size 1 1/4 to 2).

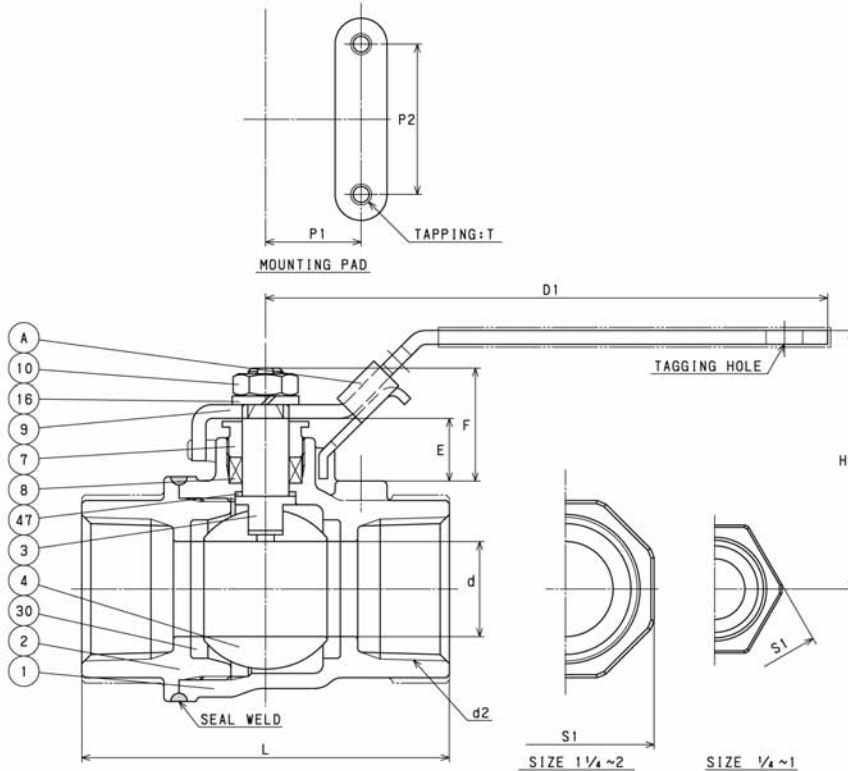

**DIMENSIONS**

Unit : inch

Nominal Size	d	H	D1	L	d2	S1	P1	P2	E	F	T
1/4	0.38	1.97	3.94	2.08	NPT 1/4	0.82	0.5	1.12	0.394	0.728	No.10-24UNC
3/8	0.46	1.97	3.94	2.08	NPT 3/8	0.94	0.5	1.12	0.425	0.760	No.10-24UNC
1/2	0.50	2.30	4.53	2.40	NPT 1/2	1.14	0.5	1.12	0.524	0.957	No.10-24UNC
3/4	0.59	2.42	4.53	2.71	NPT 3/4	1.38	0.87	1.37	0.496	0.929	No.10-24UNC
1	0.78	2.49	5.31	3.25	NPT 1	1.69	0.87	1.37	0.618	1.189	No.10-24UNC
1 1/4	1.00	2.65	5.31	3.54	NPT 1 1/4	2.09	0.93	1.5	0.614	1.185	1/4-20UNC
1 1/2	1.26	3.40	6.14	4.13	NPT 1 1/2	2.32	0.93	1.5	0.858	1.449	1/4-20UNC
2	1.50	3.64	7.48	4.61	NPT 2	2.83	0.93	1.5	0.831	1.421	1/4-20UNC



KITZ Corporation Of America  
800-772-0073 • www.KITZ.com

**THREADED CARBON STEEL BALL VALVE**  
Two Piece Seal Welded • Regular Port • Stainless Steel Trim • Hypatite Seats  
Integral Mounting Pad • Locking Oval Handle  
Firesafe in Accordance with API 607  
2000 WOG (1/4"-1") and 1500 WOG (1-1/4"-2") • NACE

**AKSCTHWZM-FSO  
CODE NO. 239-LOH**

**MATERIAL LIST**

No.	Name of Parts	Materials
1	BODY	A216 Gr. WCB
2	BODY CAP	A216 Gr. WCB
3	STEM	A276 TYPE 316
4	BALL	A276 TYPE 316
7	GLAND	A276 TYPE 304
8	GLAND PACKING	FLEXIBLE GRAPHITE
9	HANDLE	CARBON STEEL (1)
10	HANDLE NUT	A194 Gr. 8
16	WASHER	A276 TYPE 304 (SIZE 1/2 & OVER)
30	BALL SEAT	HYPATITE PTFE
47	THRUST WASHER	G/F PTFE
A	LATCH LOCK	A276 TYPE 304

**NOTE**

- (1) Plastic covering.
- (2) BS 5351 Class 800 (size 1/4 to 1), KITZ standard (size 1 1/4 to 2).
- (3) Valve rating 2000WOG (size 1/4 to 1), 1500WOG (size 1 1/4 to 2).

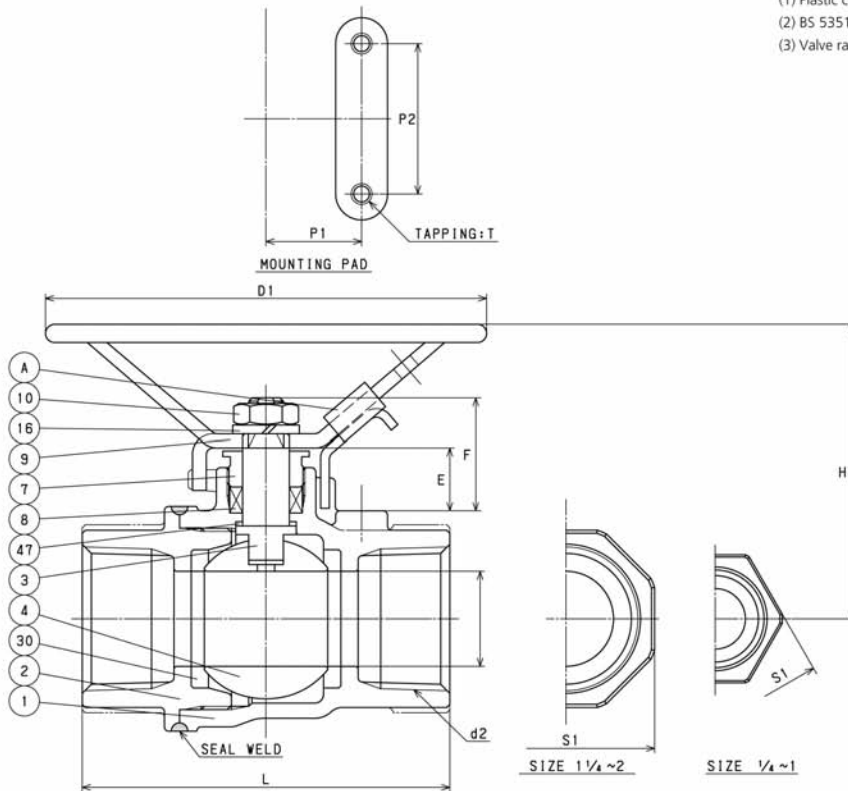

**DIMENSIONS**

Unit : inch

Nominal Size	d	H	D1	L	d2	S1	P1	P2	E	F	T
1/4	0.38	2.24	3.94	2.08	NPT 1/4	0.82	0.5	1.12	0.394	0.728	No.10-24UNC
3/8	0.46	2.24	3.94	2.08	NPT 3/8	0.94	0.5	1.12	0.425	0.760	No.10-24UNC
1/2	0.50	2.45	3.94	2.40	NPT 1/2	1.14	0.5	1.12	0.524	0.957	No.10-24UNC
3/4	0.59	2.51	3.94	2.71	NPT 3/4	1.38	0.87	1.37	0.496	0.929	No.10-24UNC
1	0.78	2.63	3.94	3.25	NPT 1	1.69	0.87	1.37	0.618	1.189	No.10-24UNC
1 1/4	1.00	2.81	3.94	3.54	NPT 1 1/4	2.09	0.93	1.5	0.614	1.185	1/4-20UNC
1 1/2	1.26	3.81	5.12	4.13	NPT 1 1/2	2.32	0.93	1.5	0.858	1.449	1/4-20UNC
2	1.50	4.03	5.12	4.61	NPT 2	2.83	0.93	1.5	0.831	1.421	1/4-20UNC