

# BUTTERFLY VALVES - 150 PSI

\*NSF372 • Lug Design • Ductile Iron Body • Extended Neck  
Bi-Directional • Booted Seat • ISO Mounting Pad • Gear Operator  
**SIZE 14" - 24"**

STANDARDS: MSS SP-67, MSS SP-25 & API-609 Cat. A      END CONNECTION: ANSI CL 125/150 FLANGES      WALL THICKNESS: KITZ STD

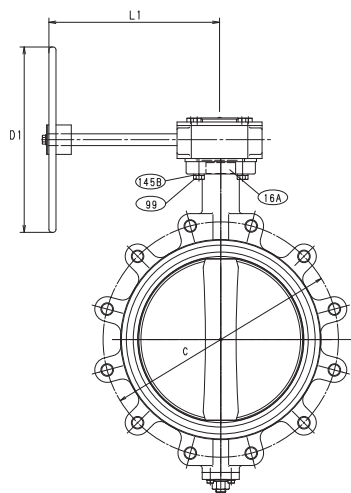
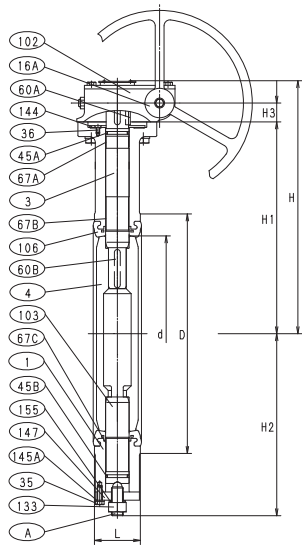

MATERIAL LIST		
NO.	NAME OF PART	SPECIFICATION
1	BODY	DUCTILE IRON (A536 Gr. 65-45-12)
3	STEM (1) (2)	STAINLESS STEEL (A276, Type 410, 420, or AISI Type 329)
4	DISC	DUCTILE IRON, AL. BRONZE, AND 316 SS
16A/B	NAME PLATE	ALUMINUM
35	END PLATE BOLTS	CARBON STEEL
36	GLAND PLATE BOLT	STAINLESS STEEL
45A/B	O-RING	NBR/EPDM
60A/B	KEY	CARBON STEEL
67A/B/C	STEM BEARING	G/F PTFE
99	SET BOLTS	CARBON STEEL
102	GEAR UNIT	
103	BOTTOM STEM (14")	STAINLESS STEEL (A276, TYPE 410 or AISI 329)
	BOTTOM STEM (16 - 24")	STAINLESS STEEL (A276, TYPE 420 or AISI 329)
106	SEAT RUBBER	NBR/EPDM
133	NUT	CARBON STEEL
144	GLAND PLATE	CARBON STEEL
145 A/B	SPRING WASHER	CARBON STEEL
147	END PLATE	CARBON STEEL
155	SEAL WASHER	CARBON STEEL
A	SUPPORT BOLT	ALLOY STEEL

(1) Type 410 is standard in 14" with D.I. and Al.Bz. disc  
(2) Type 420 is standard in 16"-24" with D.I. and Al.Bz. disc



**Code # 6111 (B/E)G**  
Disc: Ductile Iron (A536 + ENP)

**Code # 6121 (B/E)G**  
Disc: Aluminum Bronze\* (C95400)

**Code # 6131 (B/E)G**  
Disc: 316/316 SS\*

DIMENSIONS												
SIZE	d	D	C	H	H1	H2	H3	L	D1	L1	Wafer Lug	
											Lbs	Lbs
											Kgs	Kgs
in. 14	13.15	16.02	18.75	17.60	14.17	12.17	1.85	3.06	12.20	8.66	119	160
mm 350	334	407	476.5	447	360	309	47	77.7	310	220	54	72
in. 16	15.16	18.35	21.25	19.76	16.34	13.43	1.85	4.00	12.20	8.66	172	247
mm 400	385	466	539.5	502	415	341	47	101.6	310	220	78	112
in. 18	17.09	20.55	22.75	20.71	17.28	14.37	1.85	4.50	12.20	8.66	252	337
mm 450	434	522	578	526	439	365	47	114.3	310	220	114	153
in. 20	18.98	22.64	25.00	23.11	19.21	16.30	2.36	5.00	19.69	14.17	309	430
mm 500	482	575	635	587	488	414	60	127	500	360	140	195
in. 24	22.80	26.77	29.50	25.00	21.10	18.23	2.36	6.06	19.69	14.17	529	712
mm 600	579	680	749.5	635	536	463	60	153.9	500	360	240	323

For gear operator details, refer to page 24.

**NOTE:**

KITZ lug style butterfly valves are rated for bi-directional dead end service to full working pressure of the valve with the downstream flange removed. In dead end service exceeding 96 hours, a downstream flange is recommended.



\*Butterfly valves with AlBrz or SS disc conform with lead content requirements for "lead free" plumbing as defined by California, Vermont, Maryland, and Louisiana state laws and the U.S. Safe Drinking Water Act. These products further conform with the requirements of NSF/ANSI Standard 372.